

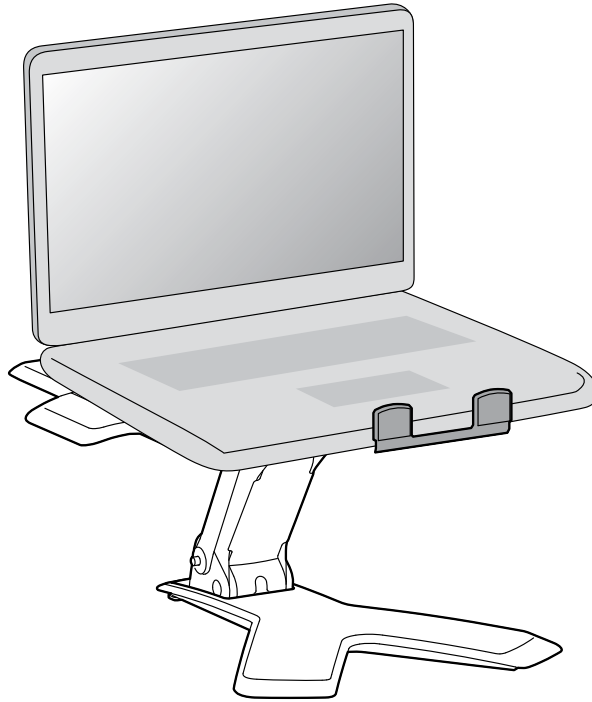

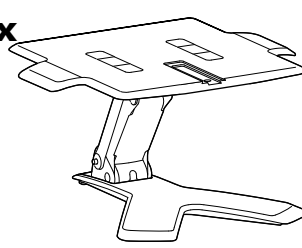



 www.ergotron.com
 USA 1-800-888-8458
 Europe +31 (0)33-45 45 600
 China 86-769-86018920



	A	B	C	D	E
1	1x 	1x 	1x 	4x 	1x 
		1x 	2x 		

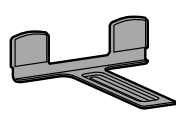

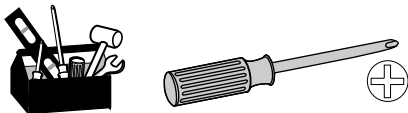
Notebook Only

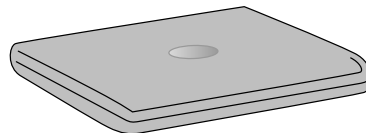

Notebook with Port Replicator

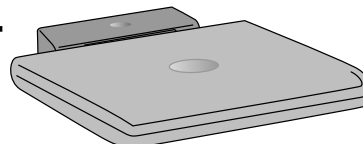

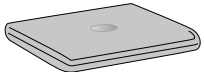

Notebook Only

1

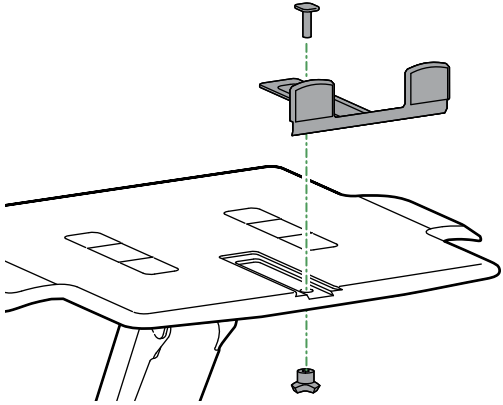

2a



Place pads where bottom surface of equipment will rest. Do not place pads where equipment's feet will rest.

4x

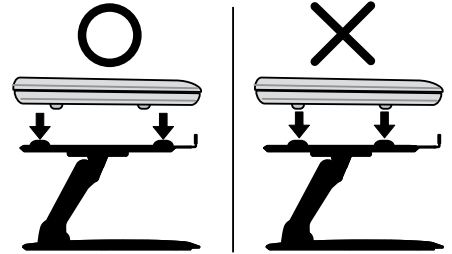
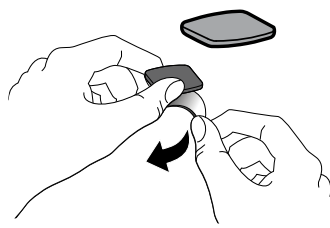

2b



All pads must be attached to the lift stand to prevent equipment from sliding.

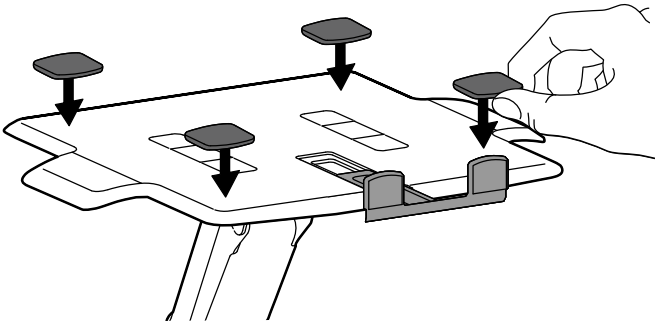

3a



Center equipment horizontally on tray.

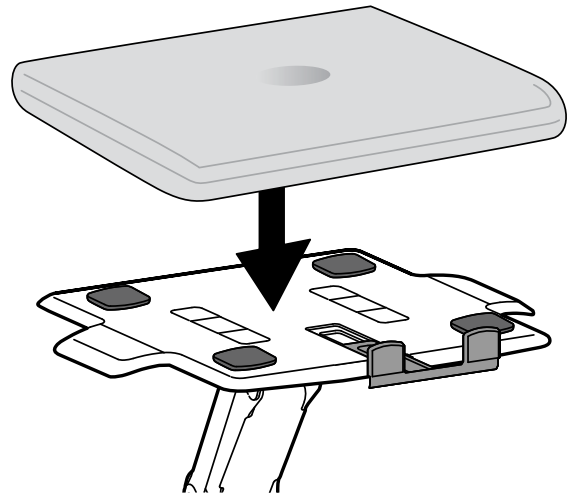

b

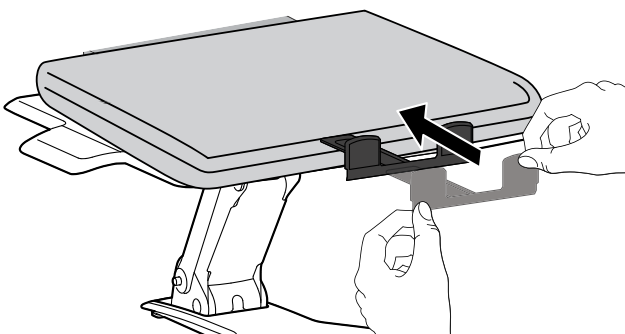

c

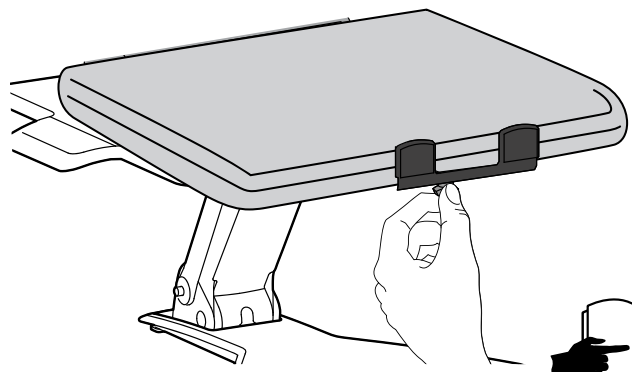

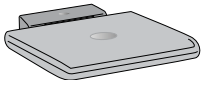

Notebook with port replicator

1

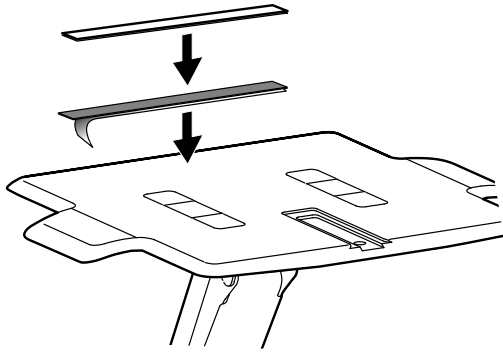

2



Center equipment horizontally on tray.

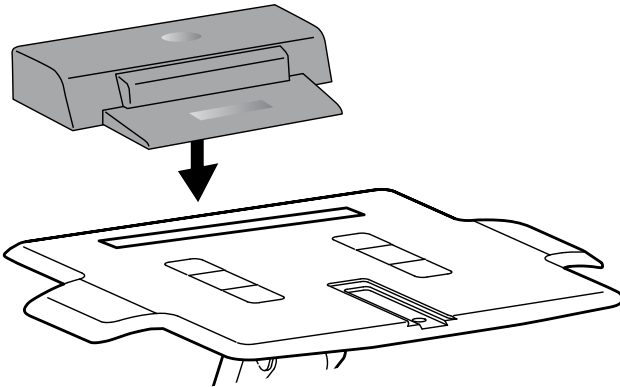

3 a

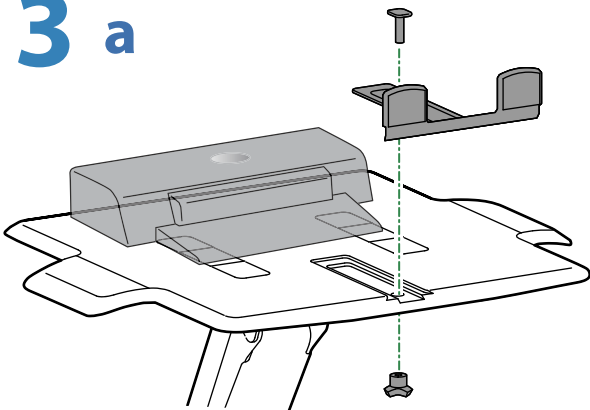

b

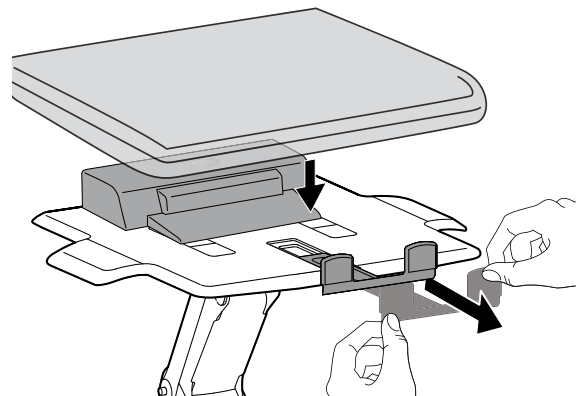

c

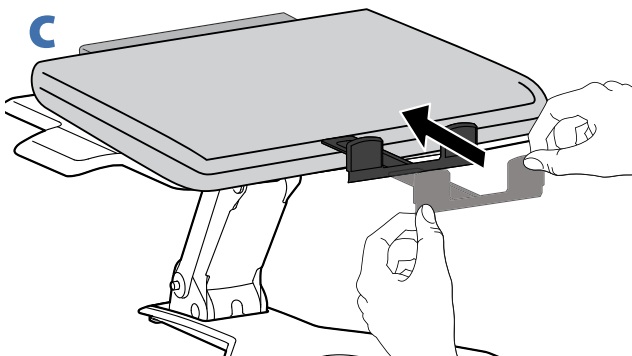

d

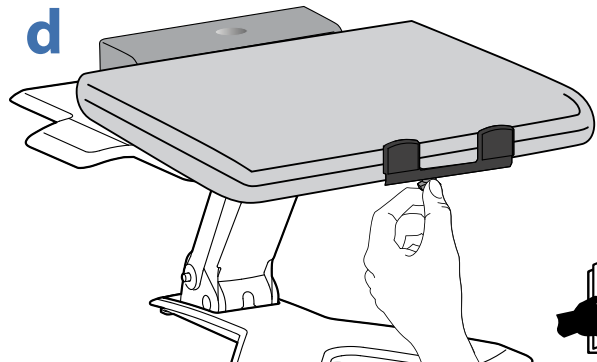

4 RANGE OF MOTION - This product is designed to adjust quickly and easily according to your needs – refer to following steps for adjustment. If it does not stay in place or movement is stiff, tension needs adjustment. Adjust until motion is equal.

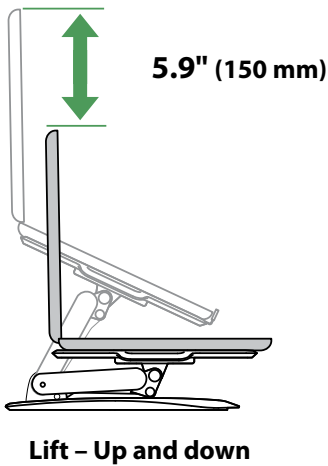

Adjust Lift – Up and down

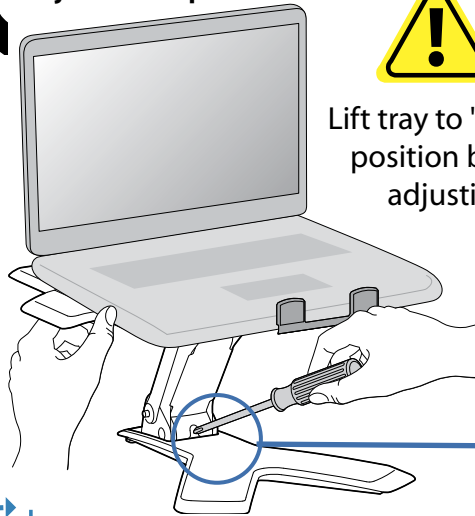

Lift tray to "full up" position before adjusting.

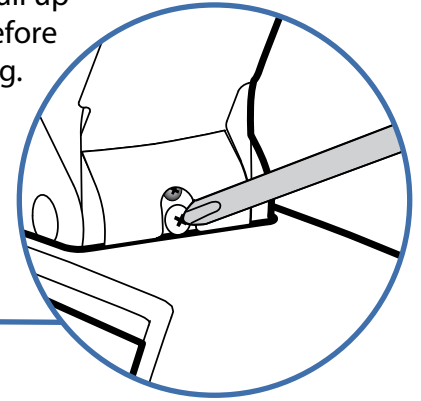
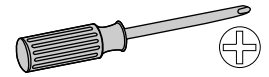

To increase tension - Turn Clockwise



To decrease tension - Turn Counterclockwise

NOTE: Screw might need to be turned about 3 - 10 full revolutions before noticing a change in tension.

RANGE OF MOTION - This product is designed to adjust quickly and easily according to your needs.

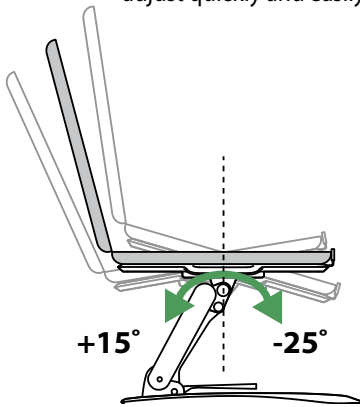

Tilt – Forward and Backward

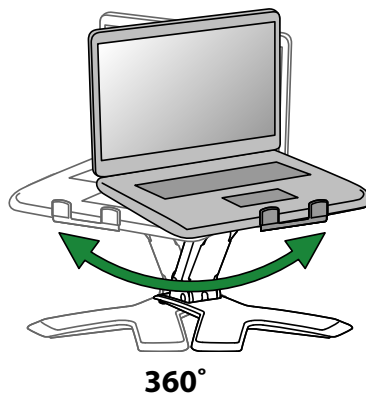



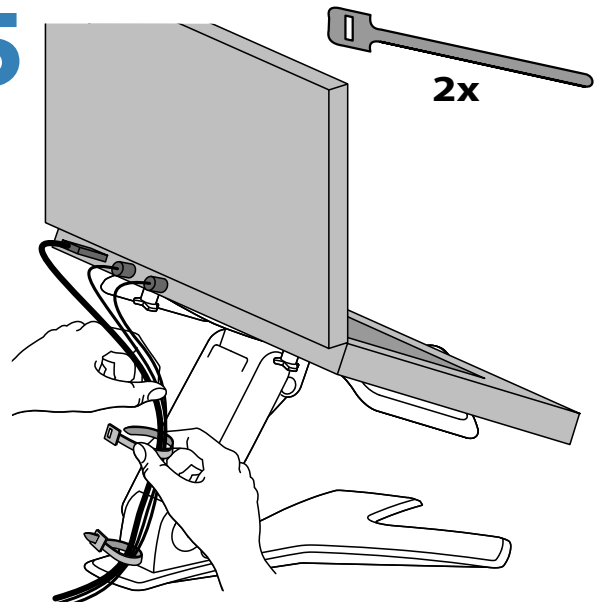

Pan – Side-to-side

5



? Trouble Shooting

Problem	Cause	Solution
Display lifts up and down too easily or with difficulty.	Tension needs adjustment.	Adjust Lift   
	Exceeds weight capacity: 3.5 - 14 lbs (1.6 - 6.4 kg).	 www.ergotron.com USA 1-800-888-8458 Europe +31 (0)33-45 45 600 China 86-769-86018920

